



# Standard Test Method for Determination of Installed Thickness of Pneumatically Applied Loose-Fill Building Insulation<sup>1</sup>

This standard is issued under the fixed designation C 1374; the number immediately following the designation indicates the year of original adoption or, in the case of revision, the year of last revision. A number in parentheses indicates the year of last reapproval. A superscript epsilon ( $\epsilon$ ) indicates an editorial change since the last revision or reapproval.

## 1. Scope

1.1 This test method covers determination of the installed thickness of pneumatically applied loose-fill building insulations prior to settling by simulating an open attic with horizontal blown applications.

1.2 This test method is a laboratory procedure for use by manufacturers of loose-fill insulation for product design, label development, and quality control testing. The apparatus used produces installed thickness results at a given mass/unit area.

1.3 This test method is not the same as the design density procedures described in Test Methods C 520 or Specifications C 739 or C 764.

1.4 The values stated in inch-pound units are to be regarded as the standard. The values given in parentheses are provided for information only.

1.5 *This standard does not purport to address all of the safety concerns, if any, associated with its use. It is the responsibility of the user of this standard to establish appropriate safety and health practices and determine the applicability of regulatory limitations prior to use.*

## 2. Referenced Documents

### 2.1 ASTM Standards:

C 168 Terminology Relating to Thermal Insulating Materials<sup>2</sup>

C 520 Test Methods for Density of Granular Loose-Fill Insulations<sup>2</sup>

C 739 Specification for Cellulosic Fiber (Wood-Base) Loose-Fill Thermal Insulation<sup>2</sup>

C 764 Specification for Mineral Fiber Loose-Fill Thermal Insulation<sup>2</sup>

E 691 Practice for Conducting an Interlaboratory Study to Determine the Precision of a Test Method<sup>3</sup>

## 3. Terminology

3.1 *Definitions*—Unless otherwise stated, the definitions listed in Terminology C 168 are applicable herein.

3.2 *Definitions of Terms Specific to This Standard:*

3.2.1 *installed thickness, n*—the average thickness, as measured immediately after application of blown insulation material when applied at a given mass/unit area.

## 4. Summary of Test Method

4.1 A standardized test chamber of 80 ft<sup>2</sup> (7.4 m<sup>2</sup>) is used as a receptacle to receive a calculated mass/unit area of pneumatically applied insulation.

4.2 The mass of insulation to be blown into the test chamber is calculated from the bag label information.

4.3 The mass of insulation prescribed in 4.2 is uniformly blown into the test chamber.

4.4 The thickness of the blown insulation is determined at 13 predetermined locations.

4.5 The thickness average of three tests is the installed thickness for the mass/unit area being tested.

## 5. Significance and Use

5.1 This test method was designed to give the manufacturer of loose-fill insulation products a way of determining what the initial installed thickness should be in a horizontal open attic for pneumatic applications.

5.2 The installed thickness value developed by this test method is intended to provide guidance to the installer in order to achieve a minimum mass/unit area for a given *R*-value.

5.3 For the purpose of product design, testing should be done at a variety of *R*-values. At least three *R*-values should be used: the lowest *R*-value on the product label, the highest *R*-value on the product label, and an *R*-value near the midpoint of the *R*-value range.

NOTE 1—For quality control purposes, testing may be done at one *R*-value of *R*-19 (h $\times$ ft<sup>2</sup> $\times$ °F/Btu) or higher.

5.4 Specimens are blown in a manner consistent with the intended installation procedure.

5.5 The material blown for a given *R*-value as part of the installed thickness test equals the installed mass/unit area times the test chamber area. This mass can be calculated from information provided on the package label at the *R*-value prescribed.

## 6. Apparatus

6.1 *Blowing Machine*—A pneumatic blowing machine, designed primarily for handling loose-fill insulation materials, shall be used for blowing the insulation into the test chamber.

<sup>1</sup> This test method is under the jurisdiction of ASTM Committee C-16 on Thermal Insulation and is the direct responsibility of Subcommittee C16.32 on Mechanical Properties.

Current edition approved July 10, 1997. Published August 1998.

<sup>2</sup> Annual Book of ASTM Standards, Vol 04.06.

<sup>3</sup> Annual Book of ASTM Standards, Vol 14.02.

This machine shall have throughput and material handling characteristics similar to that used in field applications.

6.2 *Blowing Hose*—The machine should utilize 150 ft (46 m) of 3-in. (76-mm) diameter flexible, corrugated blowing hose. At least 100 ft (30 m) of the hose should be elevated between 10 and 20 ft (3 and 6 m) above the blowing machine to simulate a typical installation configuration. The hose should have no more than eight 90° bends and no bends may be less than 4-ft (1.2-m) radius.

NOTE 2—It is good practice to clean the hose periodically by mechanically agitating it with the blower on. This practice should dislodge any pieces of insulation that might be caught in the hose.

6.3 *Test Specimen Chamber*—The specimen chamber shall be constructed in accordance with Fig. 1 with the reference dowels positioned as shown in Fig. 2.

NOTE 3—For some insulation materials it may be necessary to use a larger test chamber than shown to accommodate a more representative sample, when the test chamber size is changed, the precision may change.

6.4 *Weighing Devices*—A device is required to weigh the test material before loading into hopper. This device must determine the test material mass to within 0.5 %.

6.5 *Specimen Preparation Room*—An enclosed area where the test material is blown into the specimen chamber is required to protect the blowing operation from wind or strong air currents. Room geometry should not influence the blowing stream from the hose as long as there is adequate clearance around the sides to maneuver.

7. Sampling

7.1 Follow sampling plans given in the material specifications, regulations or other appropriate documents when applicable. In the absence of such directions, randomly select the number of bags of product required for testing to meet conditions in 8.2.

7.2 Condition the sample material by exposure in a conditioned space as prescribed by the contract or regulatory documents. If conditioning is not required, material must be in equilibrium with the storage environment.

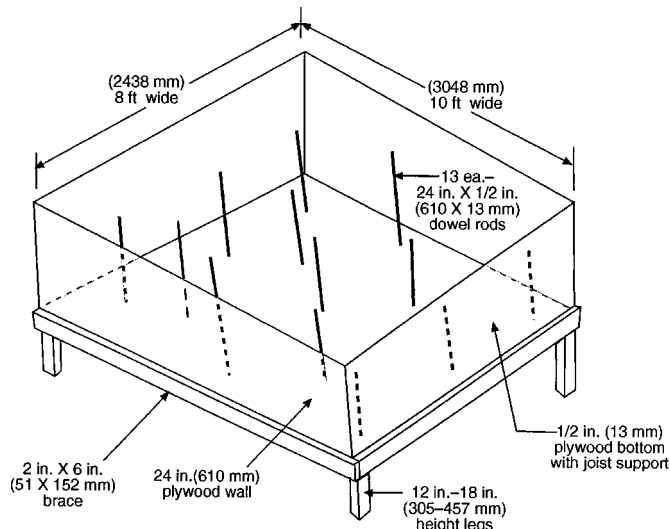

FIG. 1 Installed Thickness Test Chamber

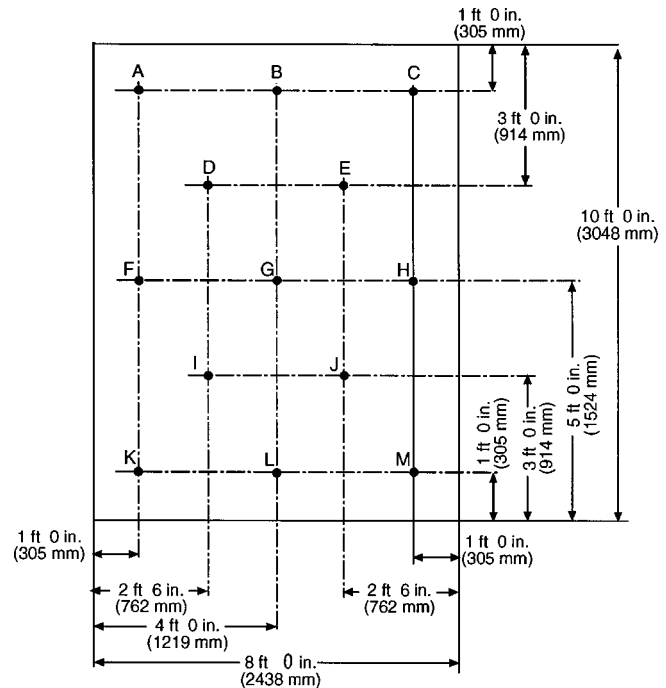

FIG. 2 Dowel Placement in Chamber Floor

8. Specimen Preparation

8.1 Clean the specimen chamber to be free of dirt and insulation prior to the start of the test.

NOTE 4—Many factors can influence the installation characteristics of blown insulation. These include blowing rate, machine adjustments, the size and length of the hose, and the angle and dimensions of the hose outlet in relation to the test chamber. Where available, use manufacturer’s instructions to establish machine settings.

8.2 From product label information, calculate the mass of insulation required to fill the test chamber for the R-value selected using the following formula:

$$W = A \times WSF \tag{1}$$

where:

- W = total mass of material required lb (kg),
- A = test chamber area, 80 ft<sup>2</sup> (7.4 m<sup>2</sup>), and
- WSF = label mass/unit area lb/ft<sup>2</sup> (kg/m<sup>2</sup>).

8.3 Assemble the blowing machine, hose, and hose length combinations as appropriate for the material being prepared (see recommendations in Section 6).

8.4 Set the blowing machine adjustments and select the feed rates in accordance with the insulation manufacturer’s recommendations. If the insulation manufacturer does not provide this information, consult the machine manufacturer for recommended settings.

8.5 Place the weighed specimen into the empty blowing machine before starting the machine. If the hopper is not large enough, fill it to capacity and have an assistant feed the remainder of insulation into the hopper as the test is progressing.

NOTE 5—If residual material is left in the machine, which cannot be blown out, then before testing the specimen material, fill machine with some insulation and blow out as much as the machine will allow. Leave the remaining amount in the machine after each trial.

**9. Test Procedure**

9.1 Blow the mass of insulation determined in 8.2 as evenly as possible by moving the hose around outside edge of test chamber. It is helpful to attach attic rulers to the inside wall of test chamber.

9.2 Return any insulation which falls outside the test chamber to the blowing machine until all material is installed within the test chamber.

9.3 Remove any material clinging to each dowel and measure the thickness of insulation to the nearest 0.25 in. (6 mm). It is helpful to slide a disc, made of approximately 5-in. (127-mm) diameter filter paper with a center hole 0.125 in. (3 mm) larger than the dowel diameter, down each dowel until contact is made with the insulation and the disc is as level as possible without compressing the insulation surface (see Fig. 3). Repeat this procedure for three trials.

**10. Calculation**

10.1 *Calculation of Installed Thickness:*

10.1.1 Total the measurements described in 9.3 and divide by the number of dowels:

$$T = \frac{\sum_{n=1}^N t_n}{N} \tag{2}$$

where:

- $T$  = installed thickness for each trial (in.),
- $t$  = installed thickness at each dowel (in.), and
- $N$  = total number of dowels.

10.1.2 Add the installed thickness from each trial and divide by three. This number will be the installed thickness for that  $R$ -value's mass/unit area.

$$T_I = \frac{T_1 + T_2 + T_3}{3} \tag{3}$$

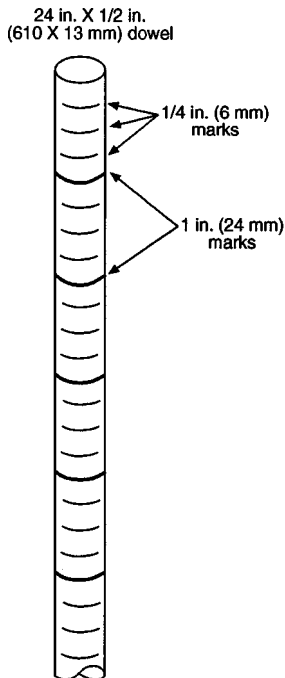

**FIG. 3 Dowel Markings**

**TABLE 1 Precision for Cellulose Insulation**

Three Specimens/Five Laboratories		Repeatability		Reproducibility	
R-Value (h-ft <sup>2</sup> ·°F/Btu)	Mean Thickness (in.)	$r$	% of Mean	$R$	% of Mean
11	4.21	0.4447	10.6	0.5808	13.8
22	7.31	1.1333	15.5	1.6572	22.7
30	9.47	0.7266	7.7	1.8799	19.8

**TABLE 2 Precision for Fiberglass Insulation**

Two Specimens/Three Laboratories		Repeatability		Reproducibility	
Material	Mean Thickness (in.)	$r$	% of Mean	$R$	% of Mean
A	7.75	0.6261	8.1	0.9096	11.7
B	8.22	1.1217	14.8	1.4425	17.6

where:

$T_I$  = installed thickness (in.).

**11. Report**

11.1 Report the following information, including references to applicable specifications and test method:

11.1.1 The name, address, and other identification of the test laboratory and the date of the report.

11.1.2 The name and other identification of the material or product tested and the date of the test.

11.1.3 The source of the material or product, the date obtained, method of sampling and the manufacture date, if available.

11.1.4 The method and details of the specimen preparation, including blowing machine and machine settings used.

11.1.5 The method and conditions of specimen conditioning if any.

11.1.6 The installed thickness and the mass/unit area used.

11.1.7 Any other pertinent observations or remarks.

**12. Precision and Bias**

12.1 *Precision*—The test results for representation of the performance of the material or product will depend not only on the characteristics of the test but also on the variability of the material or product and its sampling and specimen preparation.

12.1.1 Table 1 shows an estimate of precision based on an interlaboratory test conducted in 1992. Seven laboratories contributed data with full results secured from five laboratories on a commercially available cellulose insulation material from one production batch. Triplicate specimens of three weights of insulation corresponding to  $R$ -11, 22, and 30 (h×ft<sup>2</sup>×°F/Btu) were evaluated using this procedure (with the exception of ten instead of thirteen dowel rods).<sup>4</sup>

12.1.2 Table 2 shows an estimate of precision based on another interlaboratory test conducted in 1996. Four laboratories contributed data with full results from three laboratories using fiberglass insulation from one production

<sup>4</sup> Data is available at ASTM Headquarters. Request Research Report RR:C-16-1022.

**TABLE 3 Weight/Ft<sup>2</sup>**

	Product A		Product B	
	Bag 1	Bag 2	Bag 1	Bag 2
Laboratory 1	0.379	0.378	0.385	0.374
Laboratory 2	0.391	0.396	0.386	0.373
Laboratory 3	0.400	0.388	0.389	0.369

batch. Duplicate specimens of two different products were evaluated. Unlike the previous round-robin which targeted specific weights/ft<sup>2</sup>, the contents of each package was installed resulting in slightly different weights/ft<sup>2</sup>, as shown in Table 3. This has the effect of producing higher or lower percentages of repeatability and reproducibility.<sup>5</sup>

12.1.3 Additional interlaboratory data are being obtained

and will be added to future revisions.

NOTE 6—Test results were evaluated using Practice E 691. Repeatability and reproducibility are herein defined as 2.8 times the corresponding standard deviation to obtain a 95% confidence level. Repeatability is the variability between test results within each laboratory, and reproducibility is the variability between test results from different laboratories.

12.2 *Bias*—No statement of bias can be made for this test method since there is no standard reference material.

### 13. Keywords

13.1 cellulose; cellulosic fiber; fibrous glass; installed thickness; insulation; loose fill; mineral fiber; pneumatically applied; thermal insulation; thickness

<sup>5</sup> Data is available at ASTM Headquarters. Request Research Report RR:C-16-1023.

## APPENDIX

### (Nonmandatory Information)

#### X1. ROUND ROBIN WITH FIBERGLASS INSULATION

X1.1 Table X1.1 shows an estimate of precision based on

**TABLE X1.1 Precision for Fiberglass Insulation**

Three Specimens/Four Laboratories		Repeatability		Reproducibility	
R-Value (h-ft <sup>2</sup> ·°F/Btu)	Mean Thickness	<i>r</i>	% of Mean	<i>R</i>	% of Mean
11	6.51	0.6347	9.8	0.7781	12.0
22	11.36	1.3802	12.2	2.8882	25.4
30	14.11	0.9195	6.5	3.1949	22.7

an interlaboratory test conducted in 1992. Five laboratories contributed data with full results from four laboratories using a commercially available fiberglass insulation material from different production batches. Triplicate specimens of three weights of insulation were evaluated corresponding to R-11, 22, and 30 (h × ft<sup>2</sup> × °F/Btu) using this procedure. Since the material selected for testing came from different production batches and different production facilities, material variability will influence the precision along with the test method.<sup>4</sup>

*The American Society for Testing and Materials takes no position respecting the validity of any patent rights asserted in connection with any item mentioned in this standard. Users of this standard are expressly advised that determination of the validity of any such patent rights, and the risk of infringement of such rights, are entirely their own responsibility.*

*This standard is subject to revision at any time by the responsible technical committee and must be reviewed every five years and if not revised, either reapproved or withdrawn. Your comments are invited either for revision of this standard or for additional standards and should be addressed to ASTM Headquarters. Your comments will receive careful consideration at a meeting of the responsible technical committee, which you may attend. If you feel that your comments have not received a fair hearing you should make your views known to the ASTM Committee on Standards, 100 Barr Harbor Drive, West Conshohocken, PA 19428.*